

Müller Temperature Sensor MT

Sensor for Dynamic and Continuous Surface Temperature Measurement

Application examples:

These special thermocouples are ideal for fast measurements of temperature changes on the surface of a body. This can be the piston or cylinder surface in a running combustion engine as well as in any other continuous, but fast continuously temperature changing experiments.

The sensor is small enough to accommodate in each contour e.g. of a motor piston surface. In addition, its sensitive end can be completely inserted into the surface by filing and grinding. The dust of the grinding closes the bridge between the two metals. Alternatively, the end of the probe can be coated with a finished metal coating. This offers the advantage of a longer service life at higher temperatures, but has the disadvantage of a fixed geometry.

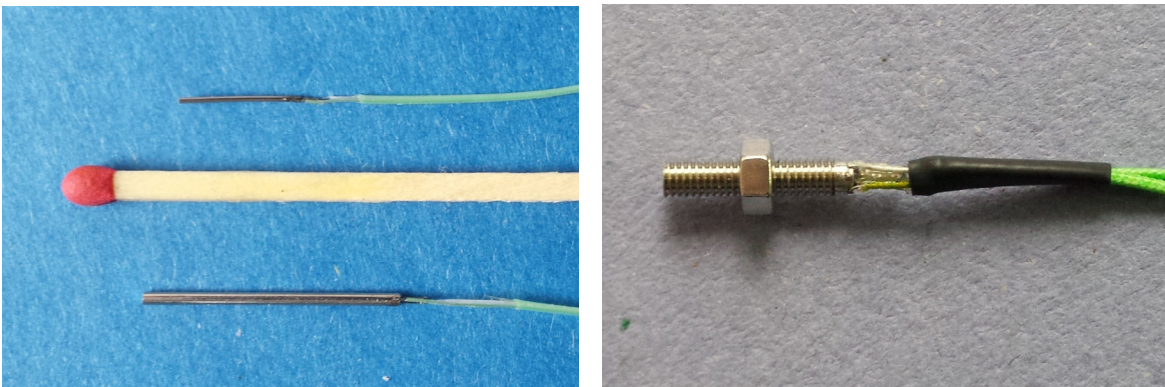

Temperature Sensor MT 047 and MT 092 and Müller-Double Head Temperature Sensor MDT 36 with thread

We offer different thermocouple for these combustion engine tests. The very small sensors MT 047 and MT 092 can be used where space is limited. The version MT 092 is a type K thermocouple. Further it comes with a DCL coating, which isolates it to the motor body to avoid additional earth loops. These small sensors will be glued into the surface. The bigger versions MT 19 and MT 36 can be used where space is not an issue. The can be glued as well or screwed with an M2 or M3.5.

If the experiment takes place at constant high temperature, the surface begins to corrode after some time and the signal disappears. The lifetime depends of the ambient temperature. From experience we know, that the lifetime in a combustion chamber is about 1 day. For much higher temperatures it may be some minutes only. If the signal gets lost, the thermocouple can be refurbished by re-grinding the sensor front surface. This gives them almost unlimited durability.

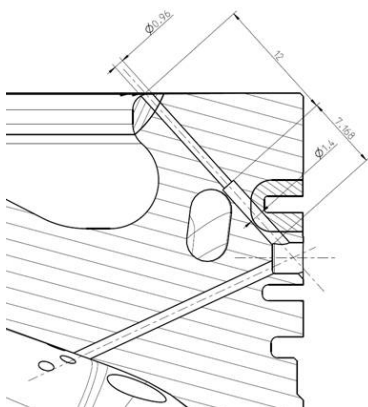

Piston of combustion engine

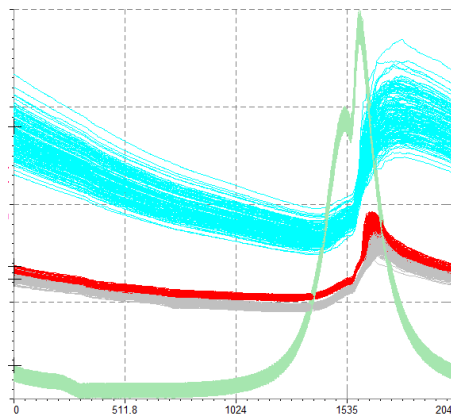

Temperature as a function of crankshaft angle

If the dynamic and continuous heat flow through the surface is of interest, this can be determined with the aid of our special Müller Double-Head Temperature Probe MDT with double-sided measurement options. This dual-head sensor allows to measure the signal on the surface at the hot end and at the same time on the back side of the thermocouple which could be the oil temperature in an engine application. For calculation of surface temperature and the heat flux through the probe follows the law of simple heat conduction. From this, the dynamic, continuous heat flow can be determined.

To calculate the temperature and heat flow out of the measured signals we offer the program Heat Flux Calculator HFC. It helps to calculate the dynamic surface temperature and heat flux in a simple manner using the signals and material data of the **sensor**.

For signal amplification we recommend our voltage amplifier MVA 10 together with a 1 MHz filter..

Technical Data

Sensor Type:	Thermocouple Type E and K
Material:	Chromel - Constantan, coaxial for type E
Temperature range:	Type E: - 200 to 900 °C Type K: - 200 to 1170°C
Temperature sensitivity:	0.5 K
Heat flux:	20 KW/m ² to 5 MW/m ²
Response time:	0.1 ms
$\sqrt{\rho c k}$	About 8000 W $\sqrt{s/m^2K}$
Diameter:	0.47, 0.92, 1.9 and 3.6
Size:	MT 047: d = 0.47 x 15 mm MT 092: d = 0.92 x 26 mm MT 19: d = 1.9 x 26 mm MT 36: d = 3.6 mm x 17 mm All sensors can be shortened in the area of their diameter
Sensitivity:	About 60 µV/K for type E, 39.9 µV/K for type K , (s. IEC-584 T1)
Calibration:	Calibrated by the University of Aachen
Tip:	Can be individually shaped by the user.
Specials:	The sensor MT 19 and 36 can be designed as a Double-Head thermocouple for measuring on the front and the back side for continuous heat flux detection
Connection:	Via 2 m temperature resistance coaxial cable with BNC pos.
Amplification:	Amplifier is needed. We recommend our MVA 10 plus 1 MHz filter
Article 100-001-0:	HFC Heat Flux Calculator program
Article 100-002-1:	MT 19, type E, diameter 1.9 mm
Article 100-002-2:	MT 36, type E, diameter 3.6 mm
Article 100-002-4:	MT 047, type E only, diameter 0.47 mm
Article 100-002-5:	MT 092, type K only, diameter 0.92 mm
Article 100-002-6:	Surcharge for metallic surface
Article 100-002-10:	Surcharge for version Müller-Double Head-Thermocouple MDT